

Automatic road
barriers
for passages
of up to
3.75 m / 12 ft



Gard 4

A new concept of automatic barrier

Innovation and design for
all-inclusive safety: these are the
most recent additions to the Gard
barrier line family.

Soft contours and rounded corners
to counteract the "sail effect" for a
barrier that incorporates perfectly
into a diversity of installation
settings.



Gard 4

230 V 24 V

Automatic road barriers

Designed for a range of large openings up to 3.75 m / 12 ft, the Gard 4 barriers are the ideal solution for control of roads and parking areas for industrial and public use.

The Gard 4 series is available in the 230 V AC motor and the 24 V DC motor versions.

The series offers many new features, all marked by innovation

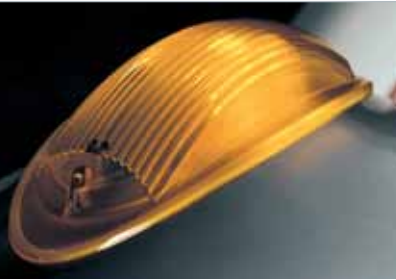

A blend of design and modern technology of illumination.

The exclusive incorporated flashing light with a lighted LED diffuser needs no special maintenance and ensures complete visibility of the warning light.



The protective guard on the bar is a standard feature.

It protects the user from possible risks when the bar is in rotation.



Perfectly integrable.

The safety photocells are applied directly onto the bar and integrate harmoniously and aesthetically with the system.

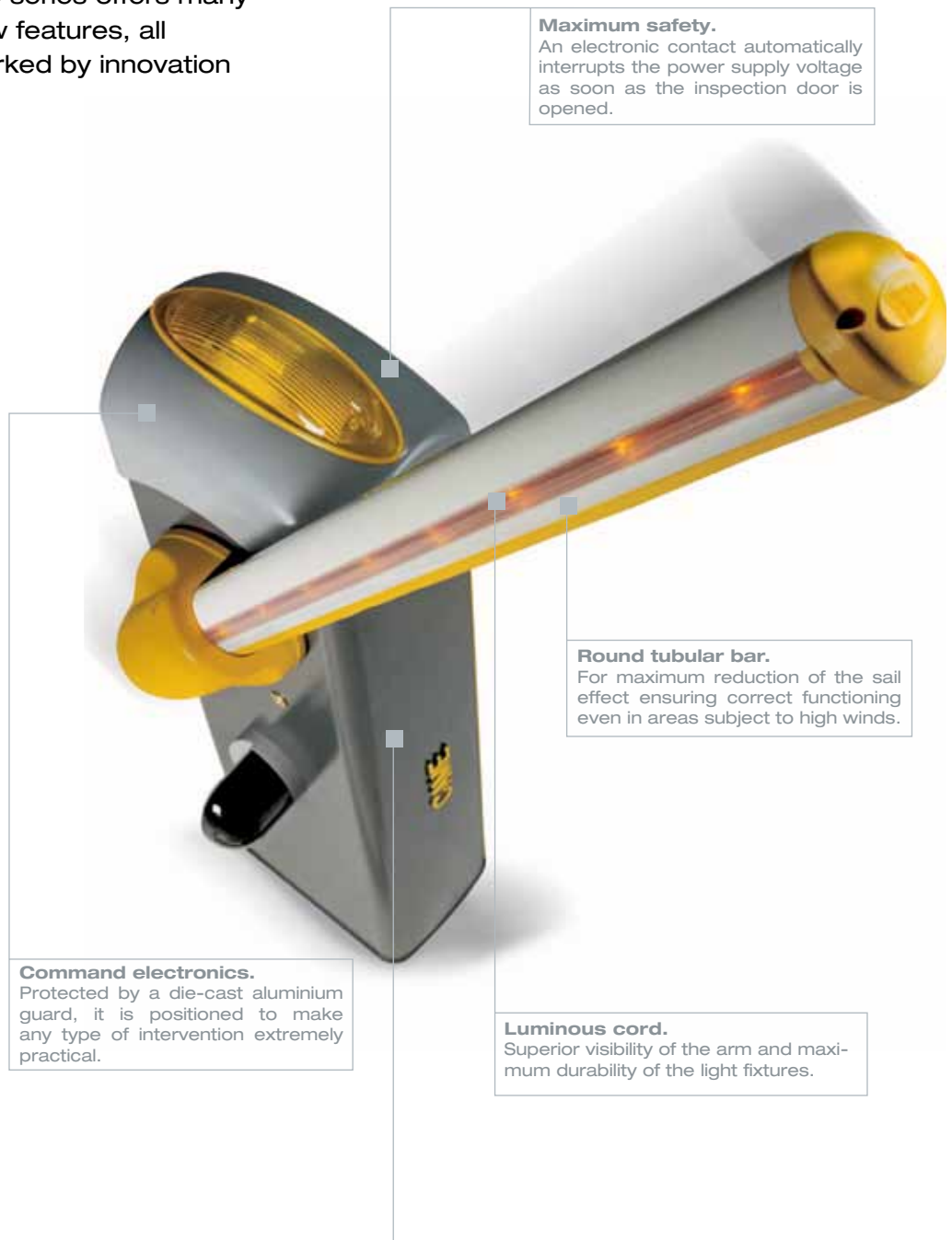

Maximum safety.

An electronic contact automatically interrupts the power supply voltage as soon as the inspection door is opened.

Round tubular bar.

For maximum reduction of the sail effect ensuring correct functioning even in areas subject to high winds.

Command electronics.

Protected by a die-cast aluminium guard, it is positioned to make any type of intervention extremely practical.

Luminous cord.

Superior visibility of the arm and maximum durability of the light fixtures.

Differentiated sensitivity spring.

For exceptional balancing of the bar.



The 230 V electronics

The Gard 4 series barriers are constructed with next-generation electronics that guarantee total control of the automatic system, improving and increasing the usual safety and control functions, such as:

- > **Comprehensive AUTOTEST of all the safety devices**
connected to the system prior to activating the motor (electronic autotest).
- > **Electronic control of the movement**
of the bar with obstacles detection (anti-crushing function).
- > **Safety feature even when the bar is stationary**
all controls are invalidated if an obstacle is detected by the safety devices.

The advantages of 24 V barriers

Streets, parking areas, collective areas or simply specific functional and security needs of the system can call for the use of a Gard system with 24V technology.

> Frequent blackouts

The electronics of a Gard 4 24 V system automatically recognize a lack of power and activate emergency operation with special auxiliary batteries.

> Keep speed in check

For total service, the 24 V electronics enable the operating speed to be adjusted depending on whether the situation requires faster or slower openings and closings.

> Intensive traffic

The low-voltage motor ensures operation of the barrier for intensive traffic conditions, such as streets, parking areas and other areas entailing constant, intensive operation.

> Rapid transit

The 24 V technology regulates the barrier opening time between 8 and 4 seconds.



Also available as a set or with synchronous action

Thanks to the additional RSE card the barriers can be installed facing each other or be synchronised with the “compass” function at the same access point.



Global entry control

The Gard series automatic barrier system can be connected to many of the Came access control systems that allow identification, memorization, and entry and exit only to authorized personnel. The equipment can also be integrated with a global access control system for specific departments in a company or the services offered by a collective structure and apartment blocks.

Made in Italy



For its quality processes management Came Cancelli Automatici is ISO 9001:2000 certified, and for its environmental management it is ISO 14001 certified. Came designs and manufactures entirely in Italy.



Road barrier with 230 V AC operator and control panel

G4041Z Galvanized and painted steel barrier complete with control panel and fitted to take additional accessories.

Road barriers 24 V DC operator and control panel

G4040Z Galvanized and painted steel barrier complete with control panel and fitted to take additional accessories.

G4040IZ AISI 304 stainless steel with satin finish bar complete with control panel and fitted to take additional accessories.

Accessories

LB38 Card for connecting n. 3 12 V - 7 Ah emergency batteries (for G4040Z and G4040IZ).

RSE Synchronised or "compass" function management card (for G4041Z).

Technical features

Type	G4041Z	G4040Z - G4040IZ
Protection rating	IP54	IP54
Power supply (V) (50/60Hz)	230 AC	230 AC
Motor power supply (V)	230 AC 50/60Hz	24 DC
Current draw (A)	1	15 Max
Power (W)	120	300
Duty cycle (%)	30	INTENSIVE USE
Torque (Nm)	220	600
Opening time 90° (s)	8	2 ÷ 6
Motor's thermo-protection (°C/°F)	150 / 302	-
Operating temperature (°C/°F)		-20 - +55 / -4 - +131

120V A.C. - 60 Hz PRODUCTS PLEASE CHECK OUR PRICE LIST ● 230 V AC ● 24 V DC

Limits to use

Model	G4041Z - G4040Z - G4040IZ
Composition of the bar	Max width of passage clearance (m / ft)
Bar with shock-resistant profile	3.75 / 12
G02803 bar with shock-resistant profile and luminous cord	3.75 / 12
Bar with G0465 rack	3.75 / 12
Bar with G02803 luminous cord and G0465 rack	3.75 / 12
Bar with shock-resistant profile and G02808 mobile support	3.75 / 12
Bar with shock-resistant profile, G02803 luminous cord and G02808 mobile support	3.75 / 12
Bar with G0465 rack and G02808 mobile support	3.5 / 11.5
Bar with G02803 luminous cord, G0465 rack and G02808 mobile support	3.5 / 11.5

● 230 V AC ● 24 V DC

Dimensions

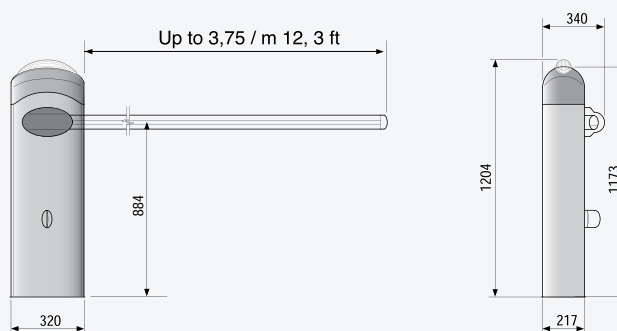

© Came KDEP#CEN19A3S10408 - 10/10

CAME
CANCELLI AUTOMATICI
S.p.A.

via Martiri della Libertà, 15
31030 Dosson di Casier
Treviso - ITALY
www.came.com - info@came.it

The data and information shown in this catalogue are subject to change without the obligation to give prior notice by Came cancelli automatici S.p.A.

